

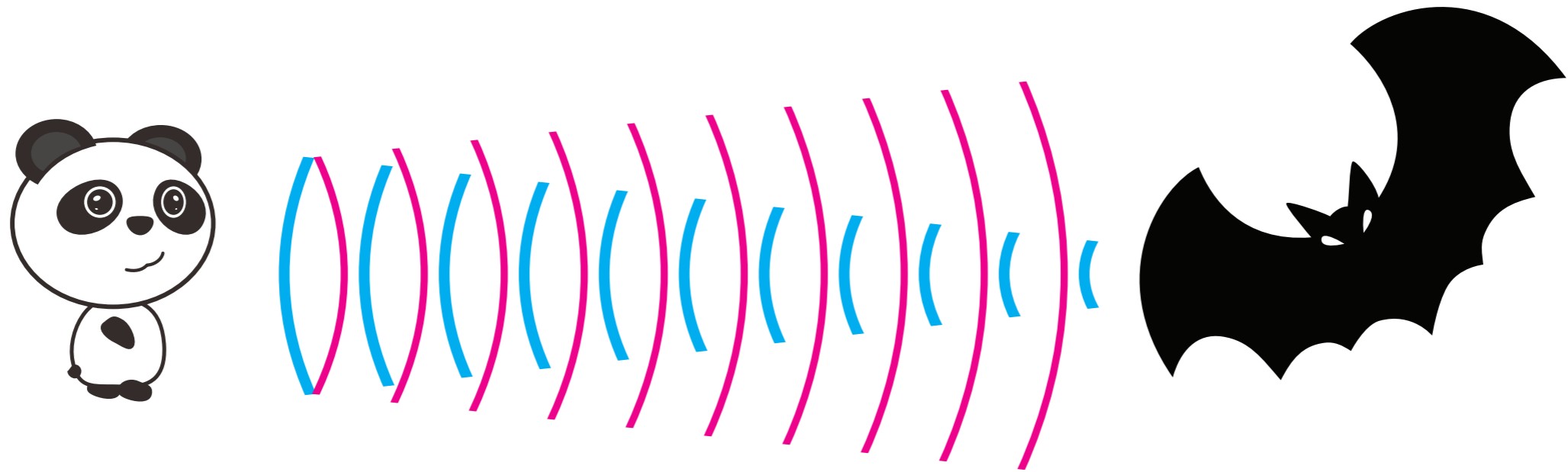

robot



geen robot



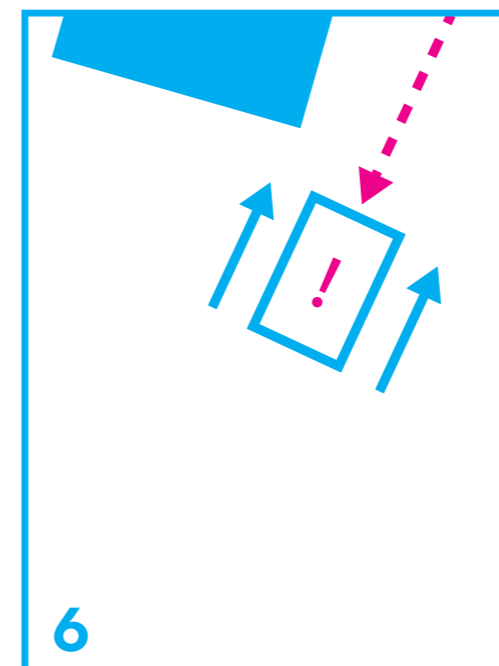
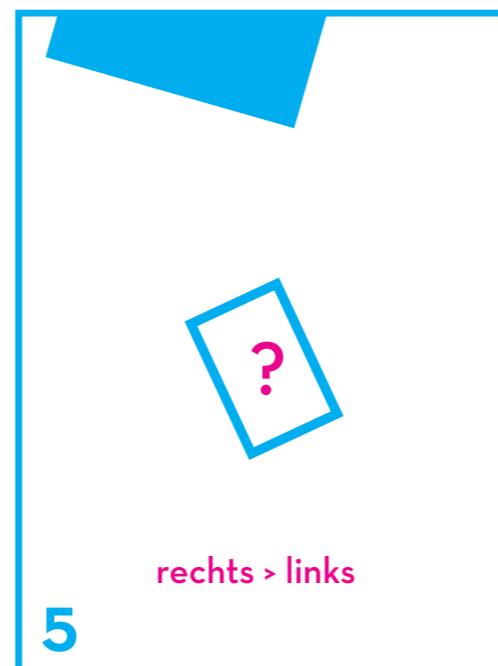
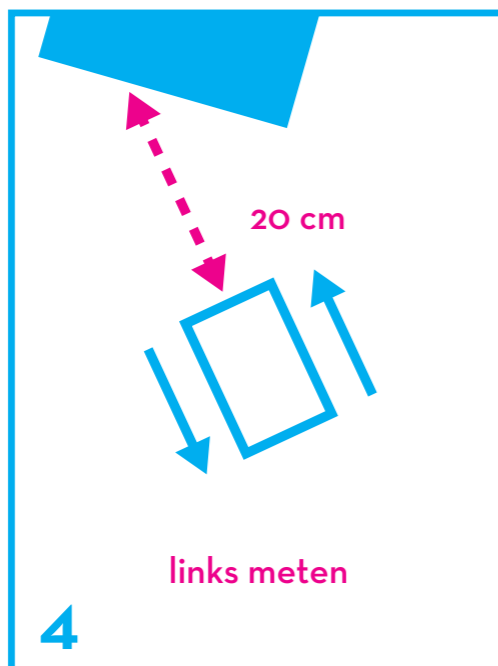
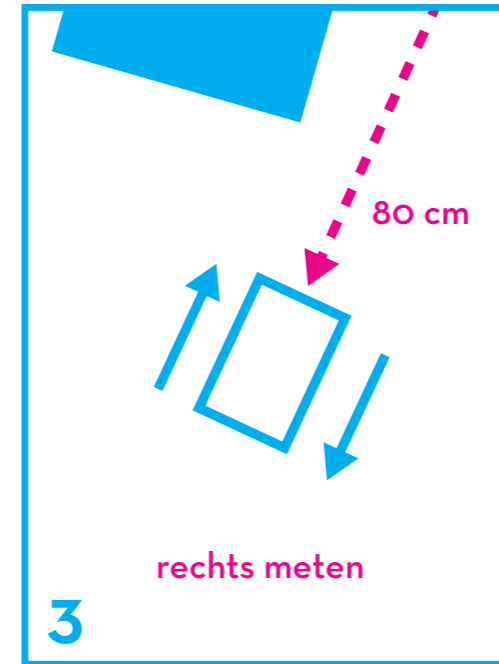
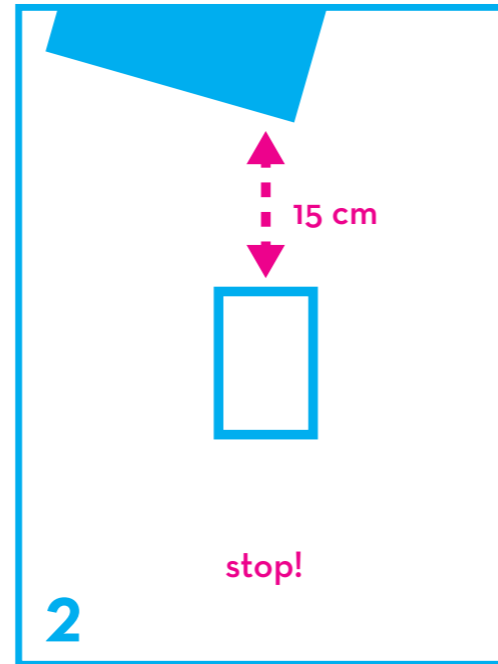
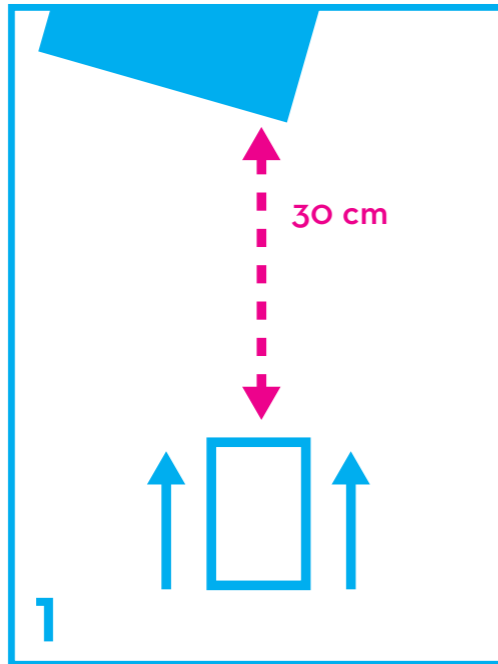

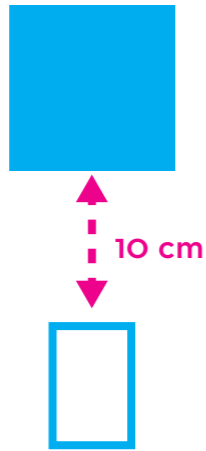

Als de robot rijdt en een obstakel meet binnen 10 cm, stop!

1

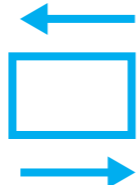

draai dan 90° naar links

2



rij klein stukje vooruit

3



draai dan 90° naar rechts

4



als de gemeten afstand kleiner dan 10cm is, ga dan terug naar stap B

5



Als de weg vrij is, rij vooruit

6